

RSE



FERRARI

THE BOX SWINGER

EMPTY CONTAINER HANDLING REACHSTACKER



CVS FERRARI's new RSE model dedicated empty container handling reach stacker is a full member of the worldwide successful F500 series of reach stackers and sure to be the star in its industry. No other machine in its class has ever been designed with the performance and in-built durability of the F500.RSE, a machine built to withstand the harshest working environment outliving and out performing its rivals. Its' superior structural design, its' higher capacity allied to superior on-board systems guarantee that the F500.RSE will be the most productive box swinger in the industry.



LOADING ABILITY
CAPACITY IN TON

F500-RSE

CTS 8'6" (9'6")	1 st row	2 nd row	3 rd row
6 th high	9	-	-
5 th high	12 (10)	9	-
4 th high	12 (12)	10 (9)	5
3 rd high	12 (12)	10 (10)	5 (5)
2 nd high	12 (12)	10 (10)	5 (5)
1 st high	12 (12)	10 (10)	5 (5)

ROBUST
RELIABLE
PRODUCTIVE

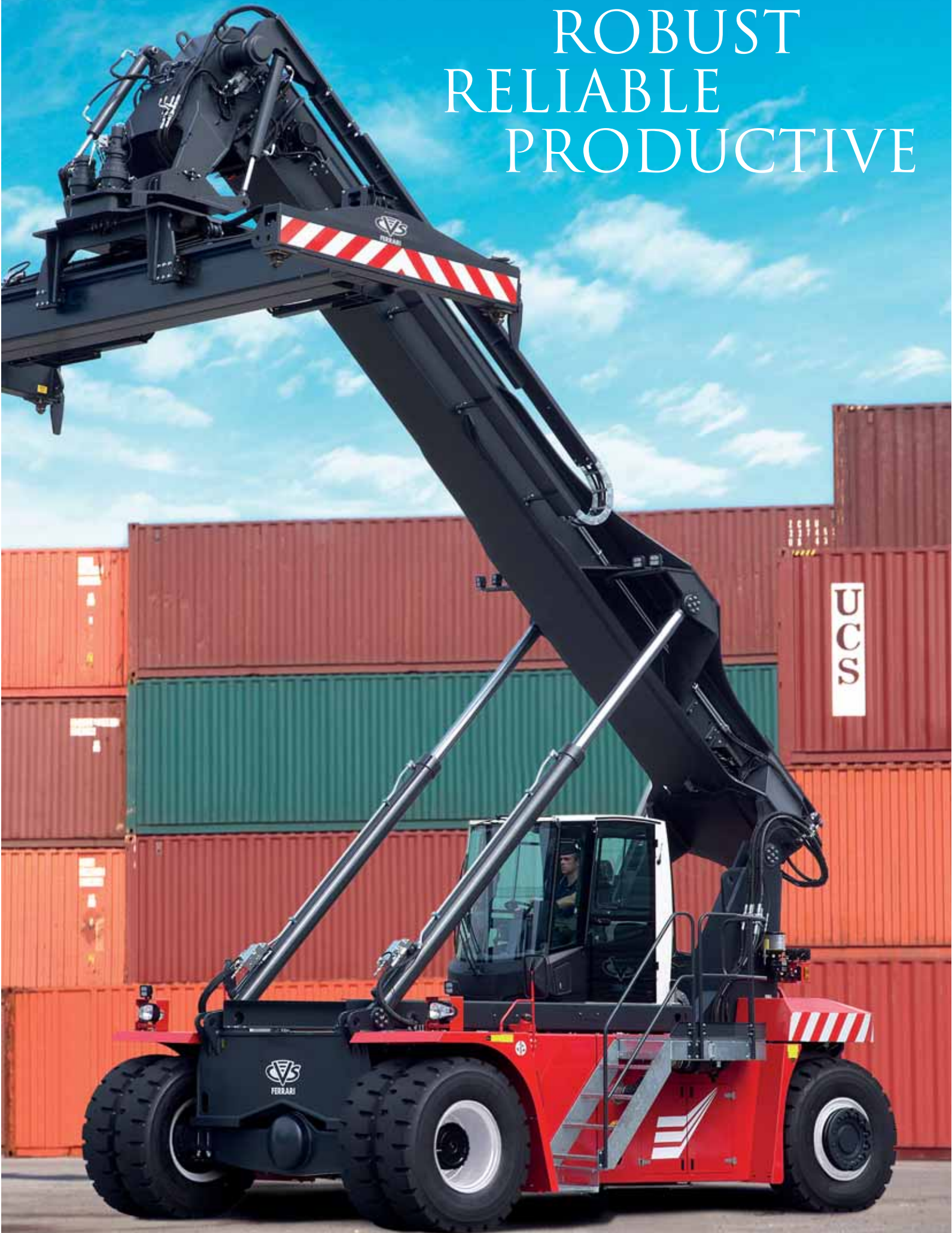



E empty container handling reach stackers require the optimum combination of maneuverability, stability and adaptability. In this specialized market segment the industry can now count on the unsurpassed design and performance of the CVS FERRARI F500.RSE - the most versatile and dependable box swinger ever developed. With twelve (12) tonne capacity in the first row the F500.RSE is the most powerful machine in its class, a fact achieved in combination with the smallest turning radius and working aisle dimension. For maneuverability and flexibility on site the choice of empty container handling reach stacker is now clear!

RSE

THE
ULTIMATE
BOX
SWINGER





The unique in house design of the spreader combines high tensile strength with reduced weight so allowing the F500.RSE to operate in the 2nd and 3rd row as well as "end-on" with both a 40' & 45' container in full safety. All this with the control afforded by our on-board computer system delivering boom-spreader anti-collision device. The spreader has a generously sized rotation gear, moved by two large gear reducers and motors controlled seamlessly by the truck on board in its' rotation and side-shift motions.



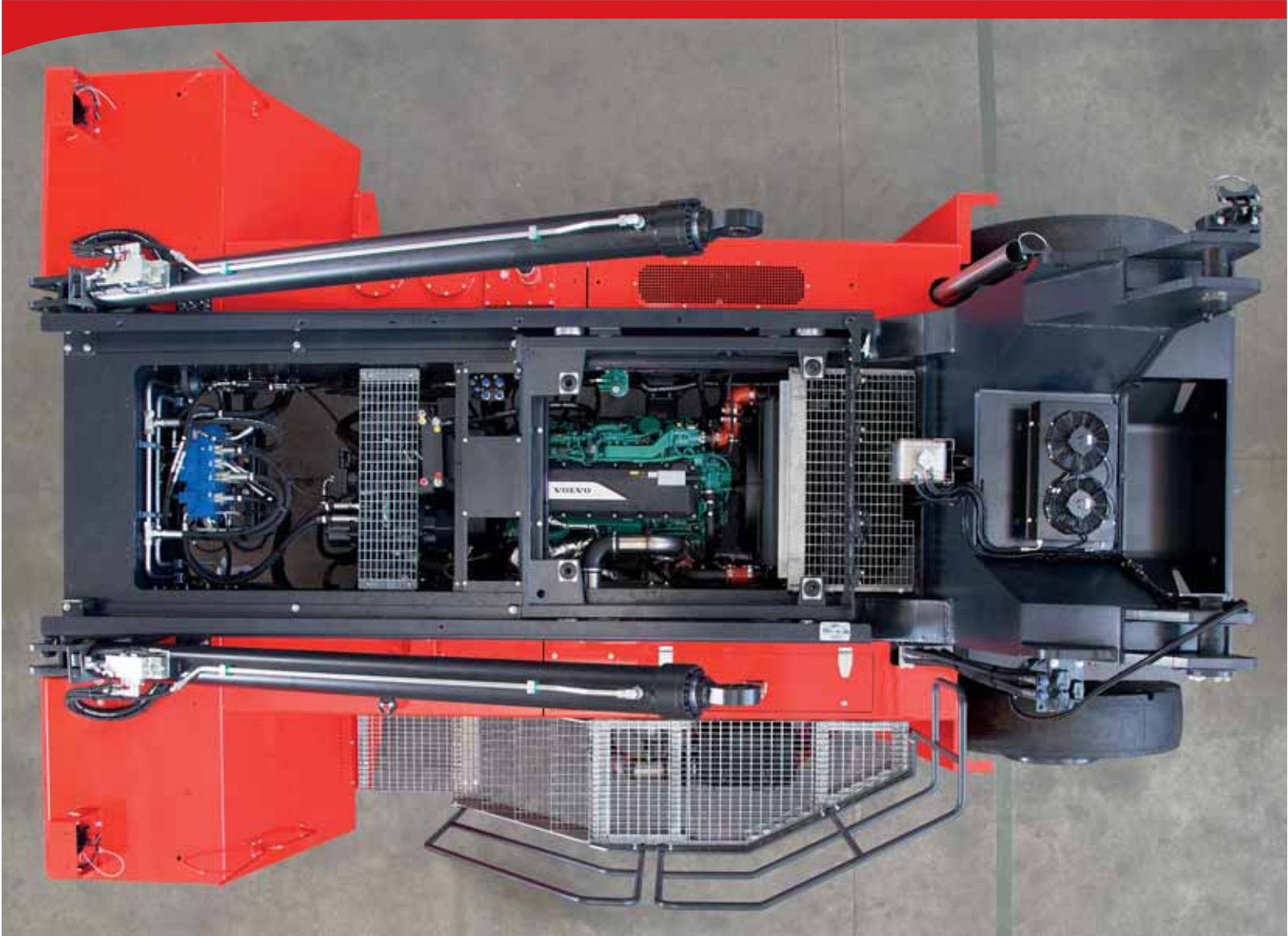

THE BEST OF THE BEST

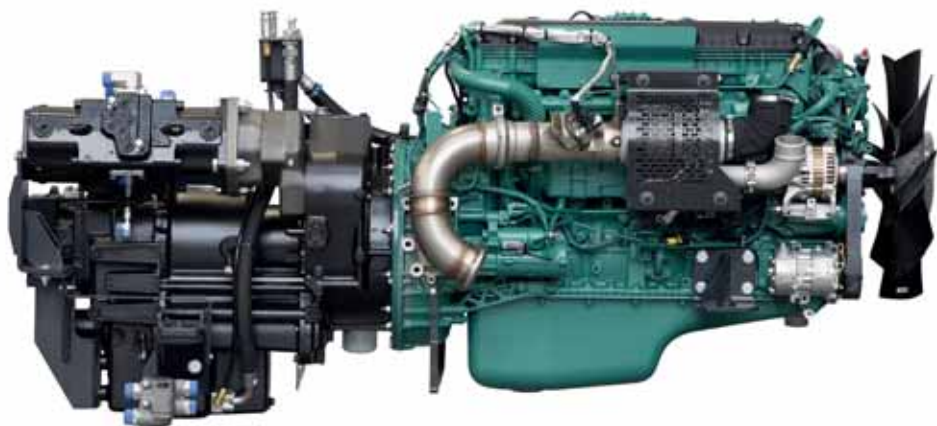

The best machines are made off the best components. So the new CVS FERRARI RSE Empty Container Handling Reach Stacker features the most powerful, advanced and fuel efficient drive train and hydraulics in the marketplace, all CAN BUS controlled and managed by the CVS FERRARI on board computer system that optimizes performances, safety, machine organs protection and energy usage.

RSE features the same high performance electronically controlled hydraulics of the CVS FERRARI F500 Laden container handling reach stackers and the same oversize hydraulic oil and wet disk brakes oil cooling system. The wide track front drive axle and the sturdy "sandwich type" ultra wide steer axle with rubber shock absorbers are standard features.

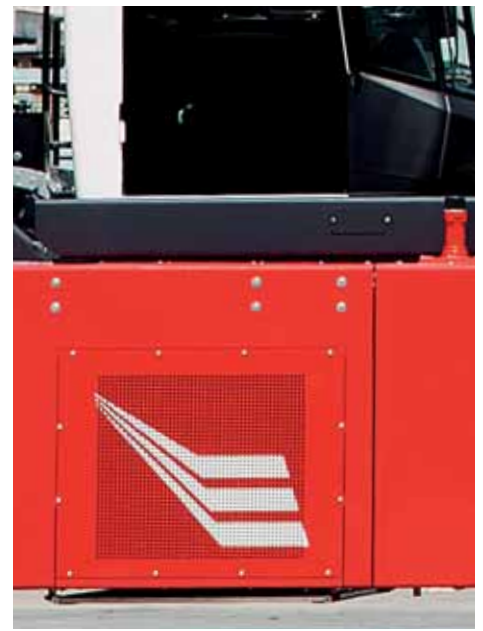

The manually sliding cab leaves complete access to the engine and transmission bay and routine maintenance tasks are made easier by conveniently repositioned fluid level refill cum check points and filters. The roomy Electric System compartment contains and protects the already all-weather proof IP 67 main electric box and system components.





The CVS FERRARI RSE Empty Container Handling Reach Stacker is coming with the supreme comfort and standard options rich CVS FERRARI ARIA cabin, that is air pressurized, excellently sound proofed and fitted with sun glare reflective glasses. The state-of-the-art joystick is capacitive type and the on-board computer has a large, graphic and colour display.



CVS FERRARI

SAFER
SMARTER
EASIER



RSE

The Industry's most modern and spacious driver's environment is complemented by the most advanced, powerful and feature-laden computer system ever delivered on this kind of equipment. The life of the user or owner of Empty container handling reach stackers has never been easier.

RSE

BETTER
THAN
EVER



CVS FERRARI RSE is the dedicated Empty Container Handling Reach Stacker with the highest lifting capacity in the marketplace and is built according to very demanding structural design requirements. Its durability and reliability are an industry benchmark and are the basis for its renowned superior productivity.

CVS FERRARI



With the all new CVS FERRARI RSE, swinging empty containers around is an easy and safe task to accomplish; also thanks to its unique compact design and excellent manoeuvrability as well as its great static and dynamic stability. Now better than ever.





FERRARI

CVS FERRARI S.P.A.
VIA EMILIA LOC FAVORITA
29010 ROVELETO DI CADEO (PC) ITALY
Tel. +39.0523.503511
www.cvsferrari.com

RSE

