

# ILF ATHENA

MACCHINA DECESPUGLIATRICE PROFESSIONALE  
PROFESSIONAL CUTTING MACHINE



MANUTENZIONE DEL VERDE  
VEGETATION MAINTENANCE



FORESTALE  
FORESTRY



VIABILITÀ INVERNALE  
WINTER ROAD SERVICE



**ILF**

SEMOVENTI  
SELF-PROPELLED



**ENERGREEN**®

Professional Machines

# DECESPUGLIATRICE AUTOSTRADALE HIGHWAY GRASS-CUTTING MACHINE



## ILF ATHENA

**ILF ATHENA** è una macchina decespugliatrice professionale che grazie ai suoi contenuti tecnologici innovativi, offre prestazioni impareggiabili, grande flessibilità e sicurezza operativa. La macchina è equipaggiata con un **braccio telescopico da 15 metri**, dove oltre alla classica testata trinciante è possibile applicare innumerevoli attrezzature. Anteriormente è possibile dotare la macchina di sollevatore con PTO oppure di piastra DIN, in modo da poter applicare un accessorio frontale da utilizzare contemporaneamente al braccio decespugliatore.

**ILF ATHENA** is a professional grass-cutting machine par excellence. Thanks to its innovative technological components, ILF ATHENA has unrivalled performances, high flexibility and working safety. The machine can be equipped with **15 meters telescopic arm**, where, in addition to the traditional cutting head, it is possible to apply various tools. In the front, the machine can be equipped with lifter and PTO or DIN plate, in order to apply a front tool to be used at the same time with the cutting arm.



# ILF ATHENA

## MULTIFUNZIONALE MULTIFUNCTIONAL

ILF ATHENA monta un braccio da 15 metri di alta qualità e grande affidabilità. Oltre alla classica testata trinciante è possibile applicare varie attrezzature per la manutenzione della grande viabilità autostradale, la cura del verde stradale e fluviale, la bonifica di aree verdi e forestali e la viabilità invernale.

ILF ATHENA model mounts a 15 meter arm of undisputed high quality and great reliability. In addition to the classic cutting head, it is possible to apply various equipment for the care of road and river green, the reclamation of green and forest areas and winter roads.

## MANOVRABILITÀ MANEUVERABILITY

- Trazione integrale: 2 ruote sterzanti, 4 ruote sterzanti e a granchio.
- Lavoro bi-direzionale.
- Four wheel drive, four steering wheels with three types of steering: 2 steering wheels, 4 steering wheels and crab steering.
- Bidirectional work.

## SICUREZZA E COMFORT SAFETY AND COMFORT

- Cabina omologata FOPS-ROPS.
- Vetro panoramico ad alta visibilità.
- Ottima ergonomia di lavoro.
- Controllo della stabilità.
- FOPS-ROPS Homologated cabin.
- High visibility panoramic windscreen.
- Excellent ergonomics.
- Stability Control.

## PRODUTTIVITÀ PRODUCTIVITY

- Lavoro in entrambi i sensi di marcia
- Manovrabilità su tutti i terreni
- Più attrezzature applicabili contemporaneamente.
- Work in both directions
- Maneuverability on all terrains
- Multiple attachments applicable simultaneously

## ESTREMA VISIBILITÀ A 360° EXTREME VISIBILITY

Massima visibilità (360°) grazie al parabrezza di grandi dimensioni per una totale e perfetta visuale dell'ambiente di lavoro  
Maximum visibility (360°) thanks to the large windscreen for a total and perfect view of the work environment

## QUALITÀ QUALITY

MY INNER+  
**STRENX**



- Telaio rinforzato in acciaio speciale STRENX®.
- Componenti certificati.
- Motore Stage V potente e collaudato.
- Trasmissioni idrostatiche HEAVY DUTY.
- Reinforced frame made of special steel STRENX®.
- Certified components.
- Powerful and tested Stage V engine.
- HEAVY DUTY hydrostatic transmissions.



BRACCIO DA 15 METRI  
15 METER ARM

CABINA ROTANTE  
ROTATING CABIN

# PUNTI DI FORZA STRENGTHS





## CABINA ROTANTE

La cabina è certificata in termini di sicurezza dai collaudi FOPS-ROPS contro il rischio di capovolgimento e contro il rischio di caduta oggetti, è adeguatamente insonorizzata, provvista di un efficiente sistema di climatizzazione e dotata di tutti quei requisiti necessari ad assicurare all'operatore un ambiente di lavoro decisamente sicuro e confortevole.

La rotazione della cabina consente di sfalciare l'erba in entrambi i sensi di marcia, senza bisogno di girare la macchina con notevole riduzione dei tempi e costi di lavoro. La cabina ruotata permette di mantenere una postura del corpo sempre corretta, evitando stress e problemi alla schiena o al collo.

## ROTATING CABIN

*Designed to meet the strict requirements necessary for FOPS-ROPS tests in terms of safety, the ILF ATHENA cabin has been developed to avoid the risks of overturning and objects fall. The cabin is adequately soundproof and equipped with an efficient air-conditioning system and all the necessary requirements in order to guarantee to the operator a completely safe and comfortable environment. The cabin rotation permit to cut the grass in both senses of direction, without having to maneuver the machine with considerable working times and costs reduction. The rotated cabin allows to keep always the body posture in the correct way, avoiding stress, backache and stiff neck.*



CABINA/CABIN  
STANDARD



CABINA/CABIN  
COMFORT



CABINA/CABIN  
PRESTIGE

## TRE STILI IN CABINA

La spaziosa cabina è disponibile in tre diversi allestimenti, per rendere il tuo lavoro sempre più facile e comodo.

## THREE STYLES IN THE CABIN

The spacious cabin certified is available in three versions, to make your work easier and more comfortable.

# COMFORT ASSOLUTO ABSOLUTE COMFORT

# 360°

## **VISIBILITÀ ESTREMA** **EXTREME VISIBILITY**

**AMPIA  
VETRATURA  
PER IL PIENO  
CONTROLLO  
DELL'AMBIENTE  
DI LAVORO**

**LARGE  
WINDOWS  
FOR THE FULL  
MONITORING  
THE WORKING  
ENVIRONMENT**

### **MASSIMA VISIBILITÀ A TUTTO CAMPO**

La prima caratteristica che colpisce appena si sale a bordo è l'ampia vetratura, che offre massima visibilità sui 360 gradi, per il pieno controllo dell'ambiente di lavoro. Il volante regolabile, come il confortevole sedile ed il sistema di comandi ergonomici ed intuitivi, creano subito un forte feeling tra l'operatore e la macchina, subito pronta a rispondere con fluidità ai comandi, per rendere leggera qualsiasi giornata di intenso lavoro.

### **EXTREME ALL-ROUND VISIBILITY**

*The first surprising feature inside the cabin are the wide glasses, that guaranties maximum visibility at 360 degrees for a full control on the working area. The adjustable steering wheel, the comfortable seat and the ergonomic and intuitive devices system establish a strong feeling between the operator and the machine with its fluidity in all drives in order to make easier every day of hard work.*



## LA CABINA THE CABIN

### MASSIMA SICUREZZA E PROTEZIONE

La cabina è omologata FOPS-ROPS garantendo la protezione contro ribaltamenti e cadute di oggetti. Essa è dotata di sistema di sigillatura attraverso morbide guarnizioni sulle vetrate fisse e mobili, montata su supporti elastici nei punti di appoggio, risulta completamente isolata ed efficientemente climatizzata rendendo la macchina adatta a lavori in ambienti polverosi e rumorosi per molte ore al giorno in completo comfort, come è nella filosofia Energreen.

### MAXIMUM SAFETY AND PROTECTION

The cabin is certified according to FOPS-ROPS regulations, which guarantees the protection against overturning and objects fall. The cabin is completely sealed through flexible gaskets fitted on all fixed and moving glasses and installed on elastic brackets on support points, is completely isolated and efficiently air conditioned. It makes the machine suitable for working in dusty and noisy situations for many hours per day giving to the operator complete comfort, which is at the base of the Energreen philosophy.



### CABINA/CABIN STANDARD

- Volante inclinabile e regolabile.
- Colonna sterzo inclinabile.
- Sedile pneumatico regolabile.
- Bracciolo regolabile con joystick.
- Computer di bordo.
- Inversore elettrico della direzione.
- Aria condizionata.
- Filtro aria condizionata anti-polline.
- Vetri posteriori oscurati anti u.v.
- Tergi lava-cristallo anteriore.
- Lampada rotante LED
- Porta cabina divisibile 60/40.
- Porta oggetti posteriore.
- Luce di cortesia interna.
- Martelletto di emergenza.
- Predisposizione alloggio estintore.
- Stacca batterie automatico.
- Presa elettrica esterna 12 volt.
- Svuota tasche laterale.
- Porta documenti.
- Accendisigari 12 volt.

- Tilting and adjustable steering wheel.
- Tilting and height-adjustable steering column.
- Adjustable air suspension seat.
- Adjustable armrest with joystick.
- On-board computer.
- Electric reverser of the direction.
- Air conditioning system.
- Anti-pollen air conditioning filter.
- Rear windows darked anti u.v.
- Front windscreen wiper.
- Rotating LED lamp.
- Divisible cabin door 60/40.
- Rear glove box.
- Internal courtesy light.
- Emergency glass breaking hammer.
- Provision for fire extinguisher.
- Automatic switch cut-off of the battery.
- External electrical socket 12 volt.
- Side pocket.
- Document holder.
- Cigarette lighter 12 volt.



### CABINA/CABIN COMFORT

#### In aggiunta all'allestimento "CABINA STANDARD"

- Cruise Control.
- Pedale inversione istantanea.
- Autoradio Bluetooth/DAB.
- Sedile con ammortizzatore lombare.
- Potenzimetro elettronico per cilindrata pompa testata trinciante.
- Tendina parasole auto-avvolgente su parabrezza.
- Fari di lavoro a LED.
- Appendi abiti.
- Specchio destro retrovisore.

#### In addition to the installation of the "STANDARD CABINE"

- Cruise Control.
- Pedal for instantaneous inversion.
- Radio with Bluetooth/DAB.
- Seat with shock absorber for the lumbar side.
- Potentiometer for changement the displacement of the implement.
- Windscreen curtain with self-wrapping.
- LED working lights.
- Coat hanger.
- Right rear-view mirror.



### CABINA/CABIN PRESTIGE

#### In aggiunta all'allestimento "CABINA COMFORT"

- Monitor con 1 telecamera.
- Secondo lampeggiante.
- Kit oblò con grata, tendina e tergicristallo.
- Tendina laterale.
- Tergicristallo laterale destro.
- Estintore.

#### In addition to the installation of the "COMFORT CABINE"

- Monitor screen with 1 camera.
- Second flashing lights.
- Porthole with grille, curtain and windscreen wiper.
- Lateral curtain.
- Windshield wiper on the right side.
- Fire extinguisher.





### ATTACCO POSTERIORE REAR ATTACHMENT

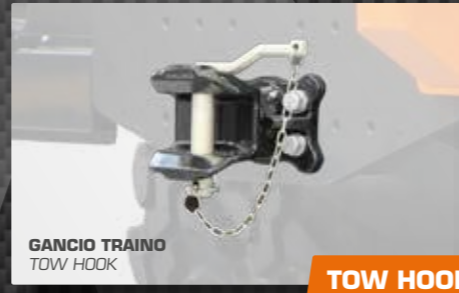
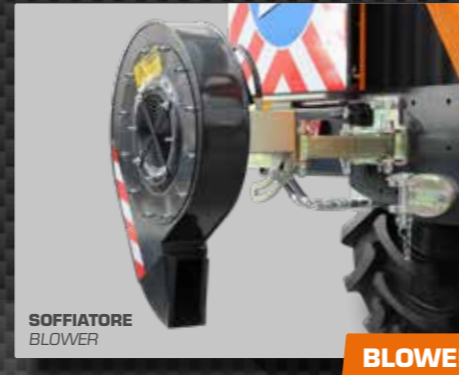

### ATTREZZATURE EQUIPMENT

L'ATTREZZO ADATTO PER OGNI LAVORO  
THE ACCESSORY SUITABLE FOR EVERY WORK

### ATTREZZATURE TERMINALI PER BRACCIO TELESCOPICO EQUIPMENT TO BE ATTACHED TO THE TELESCOPIC ARM

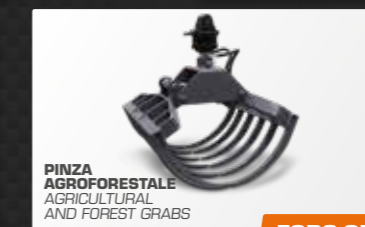
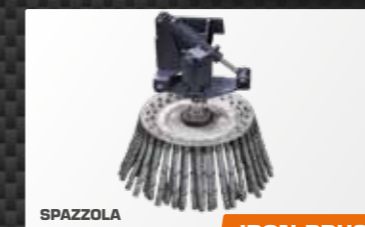
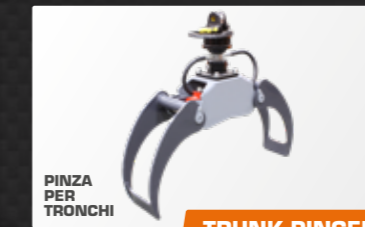

### ATTACCO FRONTALE FRONT ATTACHMENT



# MULTIFUNZIONALE MULTIFUNCTIONAL



## LUNGHE DISTANZE LONG DISTANCES



BRACCIO TELESCOPICO DA 15 METRI CON TESTATA TRINCIANTE **NEWSPEED**  
15 METERS TELESCOPIC ARM WITH CUTTING HEAD



### NEWSPEED

TESTATA TRINCIANTE  
CUTTING HEAD



- 1 Telaio in acciaio alto resistenziale  
Frame in high strength steel
- 2 Apertura idraulica frontale  
Frontal hydraulic opening
- 3 Rullo regolabile (2,5-12 cm)  
Adjustable roller (2,5-12 cm)
- 4 Cinque tipologie di rotori  
Five types of rotors

OPTIONAL  
RALLA GIREVOLE  
SLEWING BEARING

## 180°





# MANUTENZIONI AEREE AERIAL MAINTENANCE



90°

15 m

16,5 m

# ILF ATHENA

## SAWBAR

BARRA A DISCHI  
CUTTING DISCS BAR

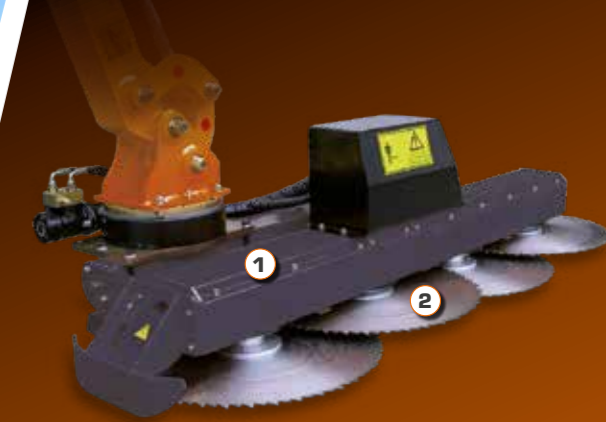

- 1 Telaio in acciaio alto resistenziale  
Frame in high strength steel
- 2 Dischi di taglio forgiati in acciaio temperato  
Forged cutting discs in tempered steel

OPTIONAL  
RALLA GIREVOLE  
SLEWING BEARING

180°



# BRACCIO TELESCOPICO TELESCOPIC ARM

ILF ATHENA è dotata di un **robusto braccio telescopico** progettato per lavorare con una estensione fino a **15 metri**, sia in profondità che in altezza. La sua particolare geometria ne esalta le caratteristiche per lavori a bordo strada anche in presenza di barriere di sicurezza alte fino a 1 metro. Lo sfilo telescopico permette di raggiungere con agilità anche le zone più lontane e difficili per operare alla manutenzione del verde sempre con la massima performance.

ILF ATHENA is equipped with a solid telescopic arm designed to work with an extension range up to **15 meters**, both in depth and in height. The special design underlines its qualities for works along the routes, even where there are security barriers up to 1 meter. The telescopic extension allows to easily reach even the furthest and narrowest areas for operating on the green maintenance always keeping the performance at the top.

**15m**



A	B	C	D	E
12,5	15	15,4	5	3



## AUTO LUBE

OPTIONAL

### SISTEMA DI INGRASSAGGIO AUTOMATICO SUL BRACCIO AUTOMATIC GREASING SYSTEM OF THE ARM

I martinetti idraulici sono composti da una testata idraulica con **saldatura a frizione (1)** con all'interno una speciale **boccola cementata in acciaio (2)** fermata da un perno in acciaio temperato. L'auto lubrificazione è garantita dalla bagnatura fatta su tutte le boccole attraverso un sistema programmato di ingrassaggio automatico, che consente una riduzione dei tempi di manutenzione.

The hydraulic cylinders are composed of a hydraulic head with **friction welding (1)** with a special steel **cement bushing (2)**, which is held by a tempered steel pin. Auto lubrication is guaranteed by the greasing on all bushes through a programmed **automatic lubrication system**, which reduces maintenance times.



# MANOVRABILITÀ MANOEUVRABILITY



1

**2 RUOTE STERZANTI  
2 STEERING WHEELS**

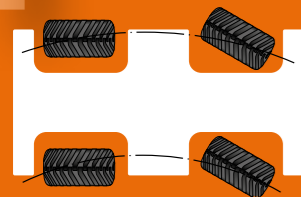

2

**4 RUOTE STERZANTI  
4 STEERING WHEELS**

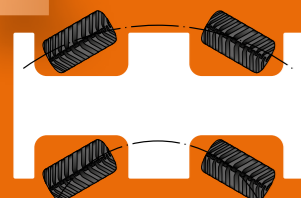

3

**MODALITÀ A GRANCHIO  
CRAB STEERING**

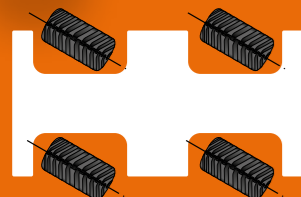

## AGILITÀ E PRECISIONE NELLE MANOVRE

La natura polivalente di questa macchina si evince anche dal sistema di trazione a 4 ruote motrici, tutte sterzanti, configurabili idraulicamente da comando in cabina in 3 diverse modalità operative:

- **2 ruote sterzanti anteriori**, per la massima agilità sui trasferimenti su strada.
- **4 ruote sterzanti**, sistema che dimezza il raggio di sterzata della macchina, adatto al lavoro in spazi ristretti.
- **4 ruote sterzanti parallele** (detta anche a granchio), utile per movimentare particolari attrezzature od allontanarsi da un ostacolo.

## AGILITY AND PRECISION IN ALL MANEUVERS

The polyvalent nature of this machine emerges also from the traction system of the four driving and steering wheels, that can be chosen hydraulically through a device placed inside the cabin according 3 different operative modalities:

- **2 front steering wheels**, for the maximum agility during road transfers.
- **4 steering wheels**, by halving the steering range of the machine, suitable for work in narrow areas.
- **4 parallel steering wheels** (called also crab maneuver), that is very useful for the movement of specific accessories or for the moving away from an obstacle.

# PNEUMATICI TYRES

**VASTA GAMMA  
DI PNEUMATICI  
SPECIFICI  
PER OGNI TIPO  
DI TERRENO  
E IMPIEGO**

**WIDE RANGE  
OF TIRES FOR EVERY TYPE  
OF TERRAIN AND USE**



**STANDARD**

**ALLIANCE  
315/80 R22.5  
GEMELLATE / DUAL**

IDEALE PER LAVORI PREVALENTEMENTE SU FONDO STRADALE  
IDEAL FOR ON ROAD ACTIVITIES

**OPTIONAL**

**ALLIANCE  
600/50 R 22.5**

IDEALE PER LAVORI PREVALENTEMENTE SU FONDO STRADALE  
IDEAL FOR ON ROAD ACTIVITIES

**OPTIONAL**

**MICHELIN  
445/70 R 22.5**

IDEALE PER ATTIVITÀ FUORI STRADA  
PNEUMATICO RADIALE  
IDEAL FOR OFF-ROAD ACTIVITIES, RADIAL TIRE

**OPTIONAL**

**TRELLEBORG  
650/45 R 22.5**

IDEALE PER ATTIVITÀ FUORI STRADA  
IDEAL FOR OFF-ROAD ACTIVITIES

# MOTORE ENGINE

**DEUTZ  
TCD 6.1**



**ILF ATHENA** monta un motore **Deutz 6.1** da **220 CV** (160 kW), 6 cilindri in linea con raffreddamento a liquido, ricircolo dei gas di scarico ed emissioni conformi a normative **EU Stage V** secondo **Direttiva EU 2016/1628** e **EPA Tier 5f**.

Il potente sistema di iniezione **Common Rail** ad alta pressione con 2 valvole per cilindro e il controllo elettronico (EMR) con collegamento intelligente alla gestione del motore, garantiscono prestazioni ottimali con un **basso consumo di carburante**.

- Minimo consumo totale di liquidi operativi rispetto alla concorrenza.
- Supporto tecnico e diagnosi forniti dalla rete di assistenza mondiale di DEUTZ.

**ILF ATHENA** is equipped with an engine **Deutz 6.1** with **220 HP** (160 kW). 6-cylinder in-line engine with liquid cooling, exhaust gas recirculation. Emissions compliant with **EU Stage V** regulations according to **EU Directive 2016/1628** and **EPA Tier 5f**.

Powerful high pressure **Common Rail** injection system with 2 valves per cylinder and electronic engine control (EMR) with intelligent connection to engine management. They guarantee optimal performance with **low fuel consumption**.

- Minimum total consumption of operating fluids compared to the competition.
- Technical support and diagnosis provided by DEUTZ's worldwide service network.

**VANO MOTORE FACILMENTE ACCESSIBILE PER LA MANUTENZIONE**  
THE ENGINE COMPARTMENT IS EASILY ACCESSIBLE FOR MAINTENANCE



# QUALITÀ DEI COMPONENTI COMPONENTS QUALITY

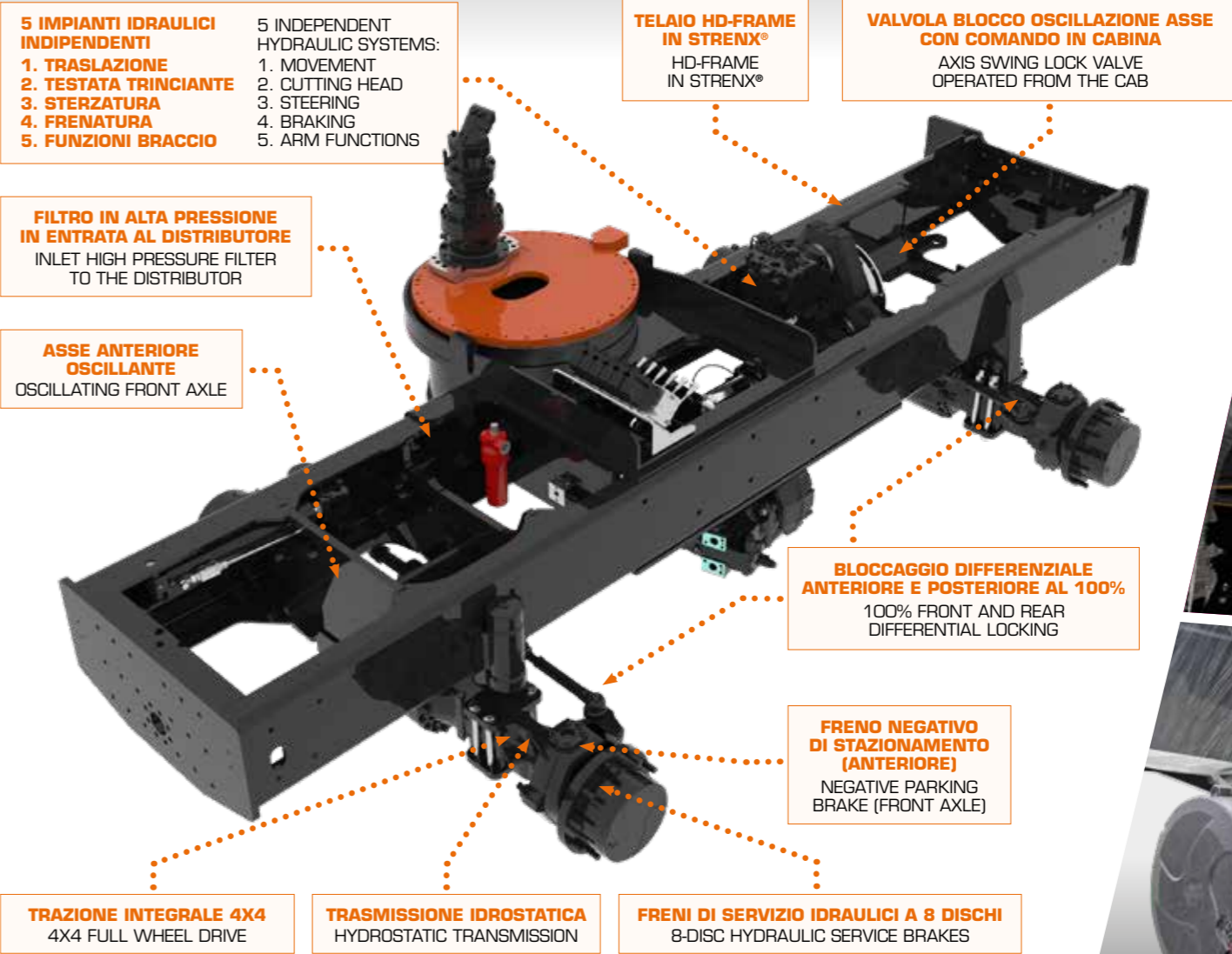

## JOYSTICK SEMPLICE E INTUITIVO SIMPLE AND INTUITIVE JOYSTICK

**INCLINAZIONE TESTATA**  
CUTTING HEAD INCLINATION

**ROTAZIONE BRACCIO**  
ARM ROTATION

**MULTIFUNZIONE**  
MULTIFUNCTION

**USCITA/RIENTRO SFILI BRACCIO**  
ARM EXTENSIONS OUT/IN

Joystick con **distributore proporzionale**, consente di muovere fino a 3 funzioni del braccio contemporaneamente con un'ottima gradualità dei movimenti, inoltre permette il bloccaggio del braccio in sospensione in qualsiasi posizione.

Joystick equipped with a **proportional distributor**, it allows you to move up to 3 arm functions at the same time with an excellent gradual movement, and also allows the arm to be suspended in any position.

## DIMENSIONI / SIZE

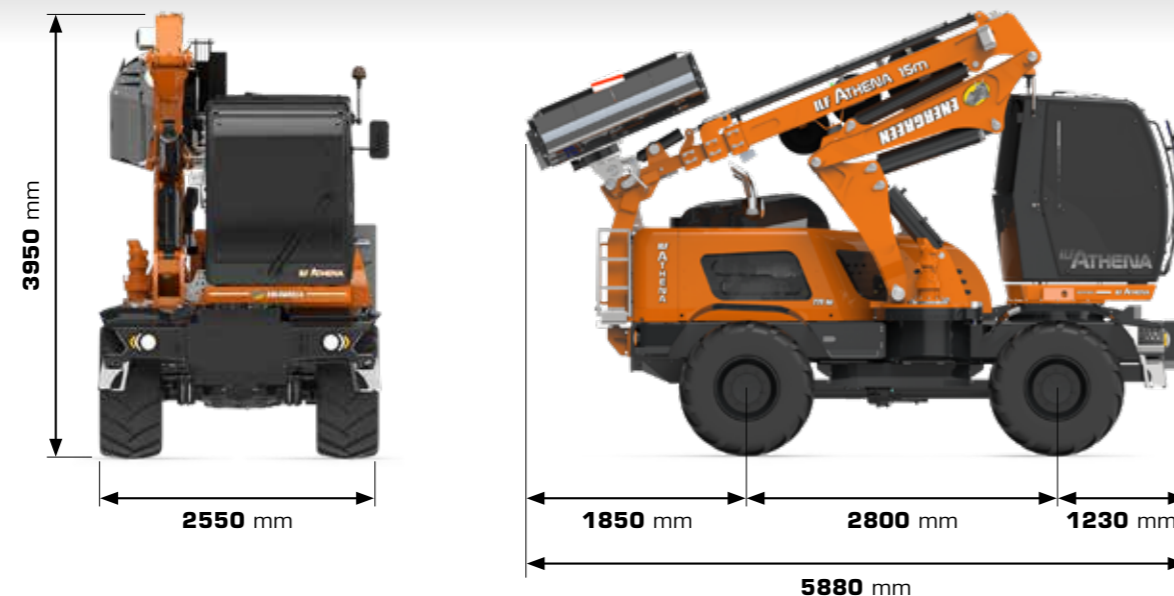

## DATI TECNICI / TECHNICAL DATA

### CABINA / CABIN

Cabina / Cabin	Girevole fino a 90° / Rotating up to 90°
Display multifunzionale / Multifunction display	Integrato al volante / Steering wheel integrated
Volante / Steering wheel	Regolabile / Adjustable
Manipolatore multifunzione / Joystick	Elettronico / Electronic
Lampada rotante / Rotary lamp	Interruttore interno cabina / Switch inside the cabin
Aria condizionata / Air conditioning	Elettronica / Electronic
Vetri posteriori cabina / Rear glasses	Oscurati / Darkened anti UV
Porta cabina / Cabin door	Divisibile / Openable 60 - 40
Sedile regolabile / Adjustable seat	Pneumatico / Air suspension
Presse elettrica servizi / Power socket	12 V
Staccabatterie / Battery switch	Automatico / Automatic
Omologazione cabina / Cabin homologation	FOPS-ROPS

### MOTORE / ENGINE

Marca / Brand	Deutz 6.1
Modello / Type	6 Cilindri Diesel / 6 Cylinders Diesel
Potenza / Power	220 hp (160 kW)
Iniezione / Injection	Common Rail DCR
Emissioni / Emissions	EU 2016/1628 Stage V - EPA Tier 5f
Alternatore / Alternator	150 A
Pre-riscaldamento aria aspirazione / Pre-heating air engine intake	
Radiatore intercooler aria-aria / Air intercooler radiator	
Computer di bordo dati del motore / Computer for visualization engine data	
Ventola reversibile autopulente / Self-cleaning reversible fan	FLEXXAIRE
Capacità carburante / Fuel tank capacity	315 litri / litres
Capacità AdBlue / AdBlue capacity	32 litri / litres

### IMPIANTO IDRAULICO / HYDRAULIC SYSTEM

Pompa e motori in circuito chiuso / Pumps and motors in closed circuits	
Pompa testata trinciante / Cutting head pump	Pistoni / Piston
Pompa traslazione / Translation pump	Pistoni / Piston

Pompa e motori in circuito aperto / Pumps and motors in open circuits

Movimenti braccio / Arm movement (LS)	Pistoni / Piston
Impianto freni / Brakes system	Ingranaggi / Gear
Impianto sterzo / Steering system	Ingranaggi / Gear
Distributore idraulico / Hydraulic distributor	Elettronico e proporzionale / Electronic and proportional
Portata olio per attrezzatura / Oil flow for attachment	160 l/min
Pressione olio per attrezzatura / Oil pressure for attachment	290 bar

### TRASMISSIONE E FRENI / TRANSMISSION AND BRAKES

Trasmissione / Transmission	Idrostatica / Hydrostatic
Trazione / Traction	4 x 4 (disinseribile / disengageable)
Variatione velocità / Speed variation	0 - 40 km/h (continuo / continuous)
Cambio meccanico / Manual gearbox	2 rapporti / 2 gears
Allineamento ruote / Wheel alignment	Elettronico / Electronic
Asse anteriore / Front axle	Oscillante / Oscillating
Bloccaggio / Front axle block	Idraulico / Hydraulic
Assi sterzanti / Steering axles	2 assi / 2 axles
Bloccaggio differenziale / Axle block	Anteriore / Front 100%
	Posteriore / Rear 100%
Freno stazionamento / Parking brake	Negativo / Negative
Freni di servizio / Service brakes	8 dischi per assale / 8 discs for axle

### DIMENSIONI E PESO / SIZE AND WEIGHT

Altezza / Height	3.95 m
Larghezza / Width	2.55 m
Lunghezza / Length	5.88 m
Interasse / Wheelbase	2.80 m
Larghezza cabina / Cabin width	1.20 m
Peso macchina senza attrezzi / Machine weight without equipment	18.000 kg
Peso testata trinciante (1.5 m) + ralla / Cutting head (1.5 m) + slewing bearing weight	460 kg

OPTIONAL  
ZAVORRA MOBILE  
MOVING BALLAST



OPTIONAL  
OBLÒ IN CABINA  
CABIN PORTHOLE



OPTIONAL  
KIT FARI DI LAVORO A LED  
LED WORKING LIGHT KIT



OPTIONAL  
MONITOR CON TELECAMERA  
MONITOR SCREEN WITH CAMERA



STANDARD  
GRADINO INTEGRATO  
INTEGRATED STEP



ILF ATHENA

ILF ATHENA DATI TECNICI & DIMENSIONI

ILF ATHENA TECHNICAL DATA & SIZE

ENERGREEN®  
Professional Machines

Caratteristiche tecniche e costruttive soggette a modifica senza obbligo di notifica - Technical and construction specifications may be subject to change without prior notice.





**ENERGREEN®**  
Professional Machines



**ENERGREEN SRL**

Via Sabbioni, 16  
36026 Cagnano di Pojana Maggiore (VI) - ITALY  
Tel. +39 0444 1511200  
Fax +39 0444 1511252

[www.energreen.it](http://www.energreen.it)  
[commerciale@energreen.it](mailto:commerciale@energreen.it)



Concessionario di zona / Local dealership



**ILF ATHENA**