

Compost turner **CMC ST 300**



Compost
Systems



The **CMC ST 300** is the next step of a long success story. For over 20 years the machine has been convincing the experts of the composting industry. Often copied but never reached, the **CMC ST 300** yet today defines the **ORIGINAL** and **LEADER**. The Model 2013 has a higher turning capacity and improved performance, stronger built trailer and rotor tunnel with better geometry. By allowing more space in the tunnel, the rotor has more working space for mixing and building the new windrow. With a capacity of ~ 1,000 m³/h and a **Rotor-Mixing-**

Index of 2.16 seconds (the **RMI** is the duration that the material spends in the rotor being mixed in one turning cycle) the all new and improved **CMC ST 300** supplies all criteria for the production of microbially-active high quality compost. For the operation of the machine a tractor of 70 hp is required. However, we recommend a tractor in the class of 80 to 100 hp equipped with a creeper gear of 200 to 750 m/h working speed. **The CMC ST 300 meets the strict criteria of Controlled Microbial Composting.**



Compost turner

CMC ST 300



Compost
Systems



Technical data

Maximum width:	3.40 m
Maximum height:	1.60 m
Rotor length:	3.00 m
Transport height:	4.00 m
Transport weight:	~ 2.30 t
incl. counter weight:	~ 5.98 t
PTO:	Bondioli
Tyres:	Standard: 12.5/80-15.3 Optional: 400/60-15.5
Color:	Grey / Blue
Tractor power:	from 70 hp
Turning quantity:	up to 1,000 m ³ /h
Working speed:	100 - 750 m/h (depending on windrow size, density, process progress)

Options:

- Hydraulic drive wheels
- Hydraulic front shovels
- Hydraulic control block
- Stainless steel rotor tunnel
- Inoculation system
- Special colors
- Irrigation boom
- 1,000 l Irrigation/innoculation combination
- 25/40 km/h-model
- Lighting system
- Brake system
- Towing hitch above PTO
- Fleece roller

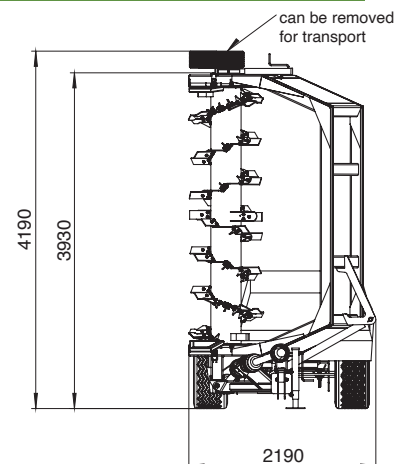
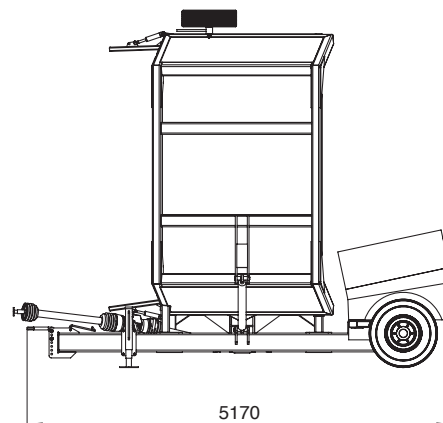
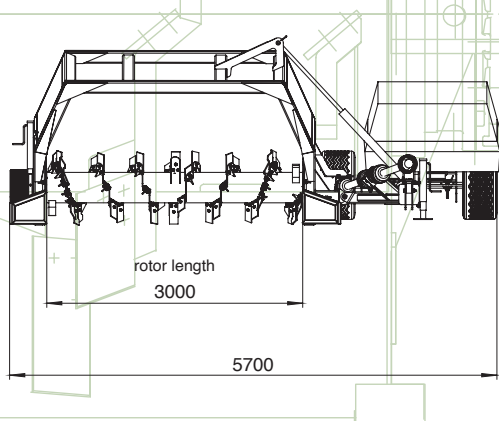

All information is subject to change without notice. Printing errors reserved.



CARACTERISTICAS **TECNICAS**

CMC
ST 300

Largura Max.	3.40m
Altura Max.	1.60m
Largura do Rotor	3.00m
Altura para Transporte	4.00m
Peso Transporte	~ 2.30 t
Incl. contrapeso	~ 5.98 t
PTO (TDF)	Bandioli
Pneus	Standard: 12,5/80-15,3 Opcional: 400/60-15,5
Cor	Cinza/Azul
Potencia Trator	Mínimo 70cv
Produtividade	Até 1.000 m ³ /h
Velocidade de trabalho	100 – 750 m/h (dependendo da dimensão e densidade das pilhas, e progresso do processo)
Opcionais	Rodas de acionamento hidráulico Pás dianteiras hidráulicas Bloco de controle hidráulico Túnel do rotor de aço inoxidável Sistema de inoculação Cores especiais Barra de irrigação 1.000 l Kit Irrigação/inoculação Modelo 25/40 km/h Sistema de luz Sistema de travagem Engate de reboque acima da tomada de força Rolo de cobertura